



**"M" Series Clutches
Installation and Maintenance Instructions
Models 300A – 700A**

**Motion Control Solutions
Regal Rexnord**
111 W. Michigan Street
Milwaukee, WI 53203
regalrexnord.com/Morse

FORM
PN 654026, PS-740-0001
4146-002E
Revised
May 2022

⚠ DANGER indicates a hazard which, if not avoided, will result in serious injury or death.

⚠ WARNING indicates a hazard which, if not avoided, could result in serious injury or death.

⚠ CAUTION indicates a hazard which, if not avoided, could result in minor or moderate personal injury.

NOTICE indicates information considered important, but not hazard-related (e.g. messages relating to property damage).

GENERAL SAFETY INSTRUCTIONS

⚠ WARNING

- Read and follow all instructions carefully.
- Disconnect and lock-out power before installation and maintenance. Working on or near energized equipment can result in severe injury or death.
- Do not operate equipment without guards in place. Exposed equipment can result in severe injury or death.

⚠ CAUTION

- Perform periodic inspections. Equipment may fail prematurely and could become unsafe if not properly inspected and maintained. Failure to follow this instruction could result in mild or moderate personal injury.

A. Preinstallation

1. It is very important that the clutch fit the shaft properly. The following are recommended shaft tolerances.

Nominal Diameter	Bore	Shaft
Up to 2"	+ .0000 / - .0010"	-.0010 / - .0020"
Over 2" to 4"	+ .0000 / - .0015"	-.0015 / - .0025"

2. On applications where a press fit is necessary, do not exceed .001 inch.
3. Should a .001 inch maximum press fit be required, immerse clutch in hot, clean automatic transmission fluid (not to exceed 200° F) for several minutes before mounting.
4. To minimize critical stresses in the keyway area of the inner race, the clutch keyways have a radius in the corners. A hardened key designed to match this keyway is furnished with stock clutches. Use this key in mounting clutch on shaft, as key must be 30-40 Rockwell C hardness and must support full length of clutch inner race. A tight fit on key width is necessary on indexing applications.
5. Orient clutch as though in operating position and check for proper rotation. Oil lubricated clutches should be mounted on horizontal shafts only. Refer vertical shaft applications to Regal Rexnord application engineering.

CAUTION! Never use the clutch as a coupling. When the connection of two shafts is required in conjunction with a clutch, use a clutch-coupling.

B. Installation

1. When mounting the clutch and key on the shaft, apply pressure to the end face of the inner race only as bearing damage could result from pressure being applied to the outer race. Caution should be exercised in installing the clutch to prevent damaging the seals.
2. Secure clutch in position on shaft. Use lock washers, snap rings, collars, adjacent components or similar items to hold clutch in position.
3. Overrun (freewheel) the clutch by hand before subjecting to test operation. Fill clutches not using reservoirs with proper lubricant. (Refer to the lubrication section.) Refer to Step #5 for installation and lubrication of reservoirs.

4. This additional step is applicable to the CAM CLUTCH COUPLING ONLY:

- a. After installing clutch and key on shaft per steps 1, 2 and 3 above, attach coupling half (*flat sprocket*) to clutch end, using capscrews provided with coupling.
- b. Mount other coupling half (*the sprocket with a hub on shaft*) onto shaft to be coupled leaving a 1/8" gap between coupling halves.
- c. Align the shafts as accurately as possible to obtain the maximum service life from the coupling.

Coupling Number	C-3	C-4	C-5	C-6	C-7
Maximum Angular Misalignment	1/2°	1/2°	1/2°	1/2°	1/2°
Maximum Parallel Misalignment	.010"	.010"	.010"	.015"	.015"
Allowable End Float From Nominal 1/8" Gap	3/32"	3/16"	3/16"	1/4"	1/4"

- d. Thoroughly pack chain and sprockets with a good quality ball bearing grease. Pack sufficient grease in cover to form reservoir.
- e. When the shafts are properly aligned, wrap the coupling chain around the coupling halves' teeth with the chain guide between the halves. Connect the chain ends by inserting the pin which is furnished loose with the coupling. The chain will wrap and connect easily on properly aligned coupling halves.
- f. Locate one cover half by use of the pilot pin furnished with coupling (see adjacent sketch), then attach cover halves together using capscrews provided with coupling.
- g. Lubricate the coupling chain and sprockets at least once a year.

B. Installation (Continued)

5. This step is applicable only when oil reservoir is used with the clutch:
 - a. Reservoirs can only be used where the clutch outer race remains stationary as in backstop applications.
 - b. Clutches are shipped with oil seals in both ends of the clutch. Remove the oil seal on the reservoir side with a screw driver or similar instrument being careful not to damage the clutch. Do this only after the proper direction of rotation of the clutch has been determined.
 - c. Prior to mounting clutch on shaft, apply Permatex®* or similar sealant to clutch key and keyway. This prevents loss of oil through keyway.
 - d. After mounting clutch on shaft per installation steps 1, 2 and 3, attach reservoir to the clutch end from which the seal has been removed, using capscrews provided with reservoir. Position reservoir with oil fill on top side.
6. This additional step is applicable only when the stub shaft adapter is used with clutch.
 - a. After mounting clutch on shaft per steps 1, 2 and 3 on page 1, attach stub shaft adapter to desired clutch end, using capscrews provided with adapter.

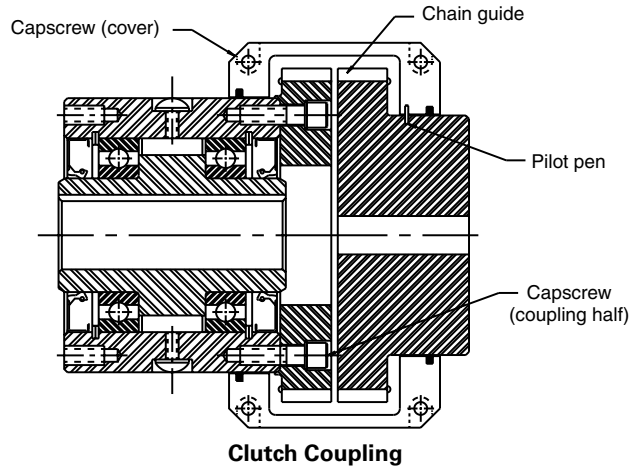

Clutch Coupling

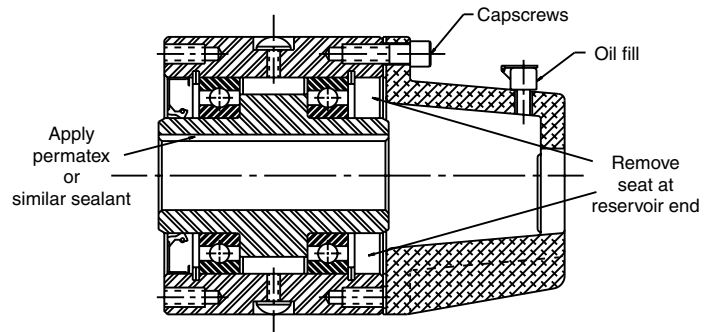

Clutch with Oil Reservoir

C. Oil Lubrication

Proper lubrication is critical to the extended service life of the clutch.

NOTICE: Oil clutches are shipped without lubricant and must be lubricated before placing on application.

1. General

- a. Automatic transmission fluid should be used for optimum performance – under normal operating conditions.
- b. To prevent internal pressure buildup a venting system is used in the inner race of the clutch. A small amount of oil may seep through this vent if the clutch is operated at low speeds. For operating speeds less than those given in the table, either plug the vent, located at the inner race keyway or lubricate with grease.

Oil Clutch, Vented	
Minimum Operating Speeds	
Model	Speed
M300A	1000 rpm
M400A	900 rpm
M500A	700 rpm
M600A	500 rpm
M700A	100 rpm

No modification should be made for speeds higher than those given in the table.

NOTICE: The temperature range for automatic transmission Fluid is -15°F. to 250°F. Special lubricants can be recommended for operating temperatures beyond the range indicated - consult Regal Rexnord Application Engineering.

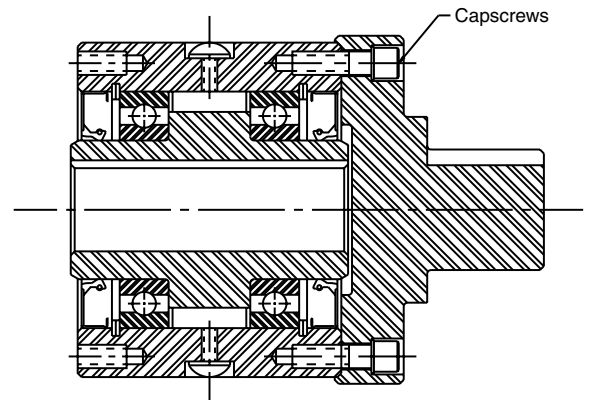

Clutch with Stub Shaft Adapter

* Permatex is believed to be the trademark and/or trade names of Illinois Tool Works, Inc. and is not owned or controlled by Regal Rexnord Corporation.

C. Oil Lubrication (Continued)

2. Oil Lubrication Procedures

- a. Standard Model MG and MR with lip seal.
 1. Rotate clutch outer race to locate filler plugs A, B, and C as shown in Figure 1A.
 2. Remove plug A and either B or C, adding automatic transmission fluid through port A until fluid shows from port B or C. Clutch will then be one-half full.
 3. Replace filler plugs, tightening to prevent leakage.
- b. Standard Model MI with lip seal.
 1. Rotate clutch outer race to locate two oil ports at positions A and B as shown in Figure 1B.
 2. Remove filler plugs A and B and add automatic transmission fluid through port A until oil flows from B.
 3. Replace filler plugs, tightening to prevent leakage.

3. Clutch Oil Capacities

Capacity - Fluid Oz.		
Size	MI	MG MR
300A	1.25	.85
400A	1.4	1.1
500A	3.0	1.8
600A	4.5	2.8
700A	10.9	4.6

4. Oil Lubrication Maintenance (Primary Maintenance Factor)

- a. Adding Oil
 1. Add automatic transmission fluid every one hundred (100) hours of operation or every two (2) weeks - whichever is first - using procedures as outlined in Section C. When clutch indexes at 150 or more cycles per minute, lubrication may be required at shorter intervals.
- b. Flushing
 1. The "M" Series Cam Clutches should be flushed periodically (90 day average) with mineral spirit solvent or kerosene. Flush more frequently if clutches are subjected to severe operation or abrasive dust.

Flushing Procedures:

1. Drain lubricant by rotating outer race so that either hole B or C is pointed down. Remove screws from holes B and C. Allow complete draining of lubricant before rotating clutch to the proper lubrication position.
2. Fill clutch with prescribed flushing agent. Install both screws B and C.
3. Rotate either clutch member slowly to break up and dissolve any oily residue.
4. Drain flushing agent from clutch — same as step 1 above.
5. Relubricate clutch according to recommended procedure.

Figure 1A

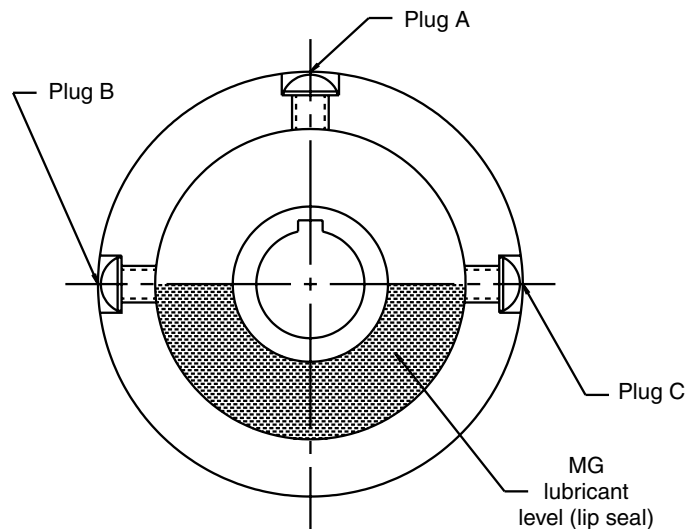
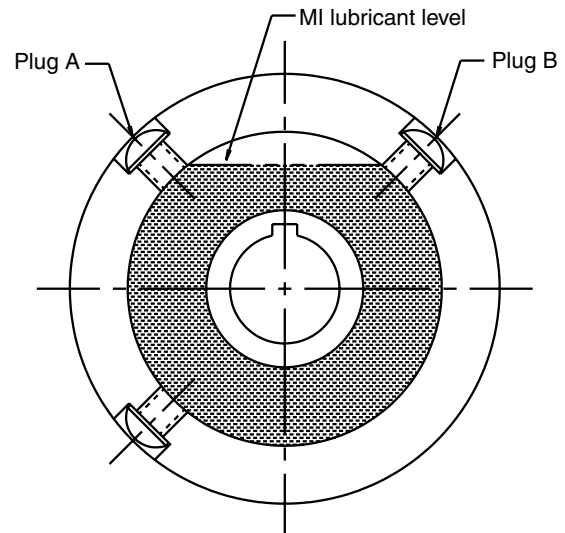

Figure 1B



D. Grease Lubrication

1. Grease Recommendation
 - a. Grease lubricated clutches are packed at the factory with Texaco™* Multifak®* AFB-2. Other compatible greases are Mobil™* SHC100 and Shell®* Alvania* #2 or equivalent premium ball bearing greases.
 - b. Grease lubricated clutches must be operated in 20°F surrounding air temperatures or higher (maximum operating temperature 200°F). Consult Regal Power Transmission Solutions Application Engineering for recommendation outside of the above range.
 - c. Do not use any lubricant with EP additives or slippery additives such as molybdenum disulfide or graphite.
2. Grease Lubrication Procedure
 - a. Stock Models MG, MR, and MI with lip seals.
 1. Clean grease fitting located on the clutch outer race by wiping with cloth.
 2. Clutch should be lubricated at grease fittings. Remove plug at position B or C. (Refer to Figure 1A).
 3. Pump lubricant into clutch with grease gun until grease flows freely from port with plug removed.
 4. Replace plug.
 - b. Standard Model MO with felt seal.
 1. Pump grease into clutch until grease flows freely from seals.
3. Grease Lubrication Maintenance
 - a. Overrunning and Backstopping
 1. Lubricate clutch every three months. If clutch is operating under severe abrasive dust conditions or twenty-four hours daily, lubricate monthly.

NOTICE: The following are general lubrication recommendations based on our experience and are intended as suggested or starting points only. For best results, specific applications should be monitored regularly and lubrication intervals and amounts adjusted accordingly.
 - b. Indexing
 1. Lubricate clutch every month. If clutch is operating under severe abrasive dust conditions or twenty four-hours daily, lubricate twice each month. Use recommended grease only.

NOTICE: Periodic flushing of grease lubricated clutches is usually unnecessary. When fresh grease is pumped in, old grease will be purged out through the filler plug holes.

*The following are believed to be the trademarks and/or trade names of their respective owners and are not owned or controlled by Regal Rexnord Corporation: Alvania, Texaco; Multifak: Chevron Intellectual Property LLC., Mobil: ExxonMobil, Shell: Royal Dutch Shell plc.

E. General Information

1. Application Engineering: 1-800-626-2093.

CAUTION! Do not use the clutch above its torque or speed ratings. Do not attempt to take this clutch apart.

"Regal Rexnord" is not indicative of legal entity.

Morse is a registered trademark of Borg-Warner Corporation, used herein under exclusive license.

Regal Rexnord and Morse are trademarks of Regal Rexnord Corporation or one of its affiliated companies.

© 2009, 2022 Regal Rexnord Corporation, All Rights Reserved. MCIM22029E • Form# 4146-002E

The logo for Regal Rexnord, featuring a stylized 'R' icon followed by the text 'Regal Rexnord' in a bold, sans-serif font.